

# OPTIPAC® VMC-15

Modular process control system

(c) 2016 mahlo GmbH & Co. KG  
Dorleustraße 12  
D-93342 Gabel-Dornau

**mahlo** VMC

Article: VARIOUS

56.8 m/min  
739.2 m  
WMR: 300.0 cm

AML FMI

Permaset VMT  
Dwell time

Famacont PMC  
Thread count

Gravimat FMI  
Grammage (G/m<sup>2</sup>)

Ecomat AML  
Exhaust air humidity

OPTIPAC® VMC-15



# OPTIPAC® VMC-15

A modular system for measuring, logging and controlling critical process parameters over the entire working width, such as dwell time, thread density, residual moisture, grammage, exhaust air moisture, etc.



### Area of application

Textile manufacturers and finishers fight with rising production and energy costs, declining profit margins, shorter production times as well as higher requirements on quality and flexibility. Cost-efficient and quality-focused textile outfitting thus becomes increasingly important. Sustained production and the trend to higher-quality, technically sophisticated textiles also play a major role.

The efficiency of the production plants can be drastically increased through suitable measuring and control technology from Mahlo. This means, at the same time, increased productivity with usually improved reproducible quality, optimised raw materials usage and work effort accompanied by clearly improved plant utilisation.

Regardless of the challenges of the textile industry – Mahlo has the right solutions ready. The broad range of applications for the textile industry by Mahlo is based on experience reaching back to the year 1945.

### Product highlights

- ✓ Modular system architecture
- ✓ Operator-friendly
- ✓ Informative process visualisation
- ✓ Online monitoring and regulation of all relevant parameters

### Customer benefits

- ✓ Increased productivity
- ✓ Optimised production security
- ✓ Increased process reproducibility
- ✓ Documentation and comparability of quality
- ✓ Considerable energy savings
- ✓ Short amortisation times

# TABLE OF CONTENTS

## BASIS

<b>Optipac VMC-15</b> Modular process control system	2
<b>Visualization</b> Everything at a glance	6

## SENSORS

<b>Permaset VMT</b> Dwell time control	8
<b>Famacont PMC</b> Weft thread and course density control	10
<b>Gravimat FMI</b> Grammage measurement	12
<b>Textometer RMS</b> Residual moisture control	14
<b>Ecomat AML</b> Exhaust air moisture control	16
<b>Wilot WMR</b> Product width	18

## TECHNICAL DATA

Technical data	20
----------------	----

The Optipac VMC is a modular process control system for textile refinement. It optimises drying or fixing processes as well as the processes all about the stenter.

The system measures, logs and regulates critical process parameters such as the following over the entire working width:

- Temperature
- Dwell time
- Residual moisture
- Exhaust air moisture
- Thread density
- Weight

This increases quality and saves resources and energy. The modular design of the system allows its flexible adaptation to all applications. Both, standard requirements and highly customized demands are thus met.

The system can also be integrated into an Orthopac straightening system. It thereby combines the functionality of a weft straightener with that of a process control system in one compact device.

Improved product quality, saving of resources and energy as well as optimisation of the production processes in a single step: with the **process control system Optipac VMC** from Mahlo.

## Principle of operation

Mahlo straightening and process control system for stenters

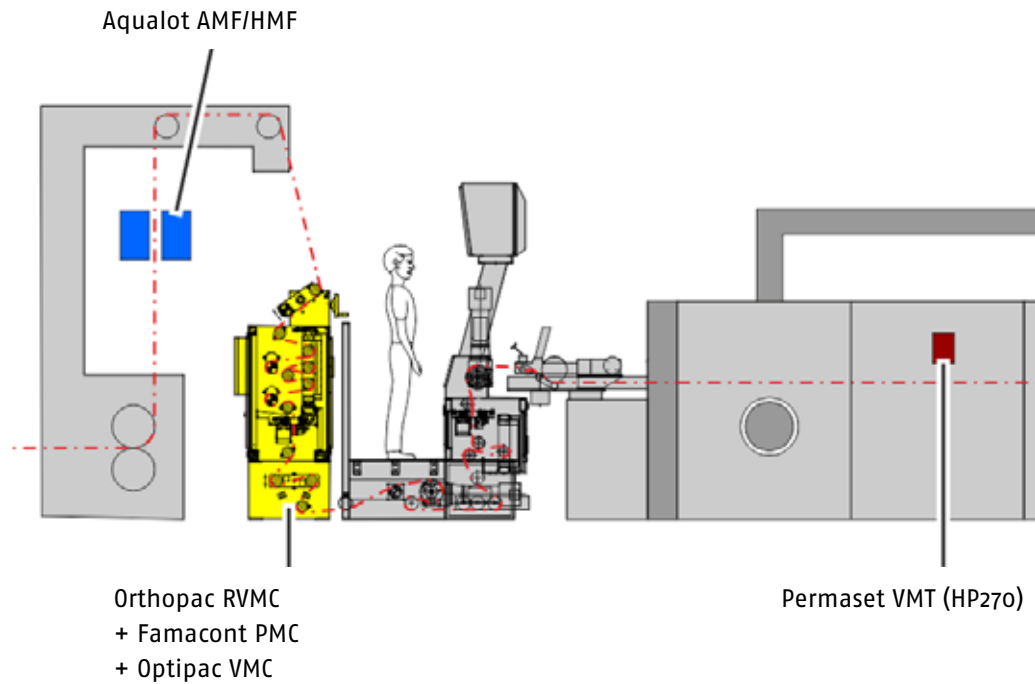

The Optipac is a modular process control system for a variety of important parameters in textile finishing. Different intelligent sensors can be connected to the base unit via a bus connection.

Different process parameters can be measured, visualized, controlled and documented by means of special software packages, e.g. Print-server.

The touchscreen of the system displays the measurements. Individually modifiable displays of the measured values facilitate easy monitoring of the complete process by the user. Configurable alarm settings always monitor the background applications. A switching option allows bringing the respective application desired to the foreground.

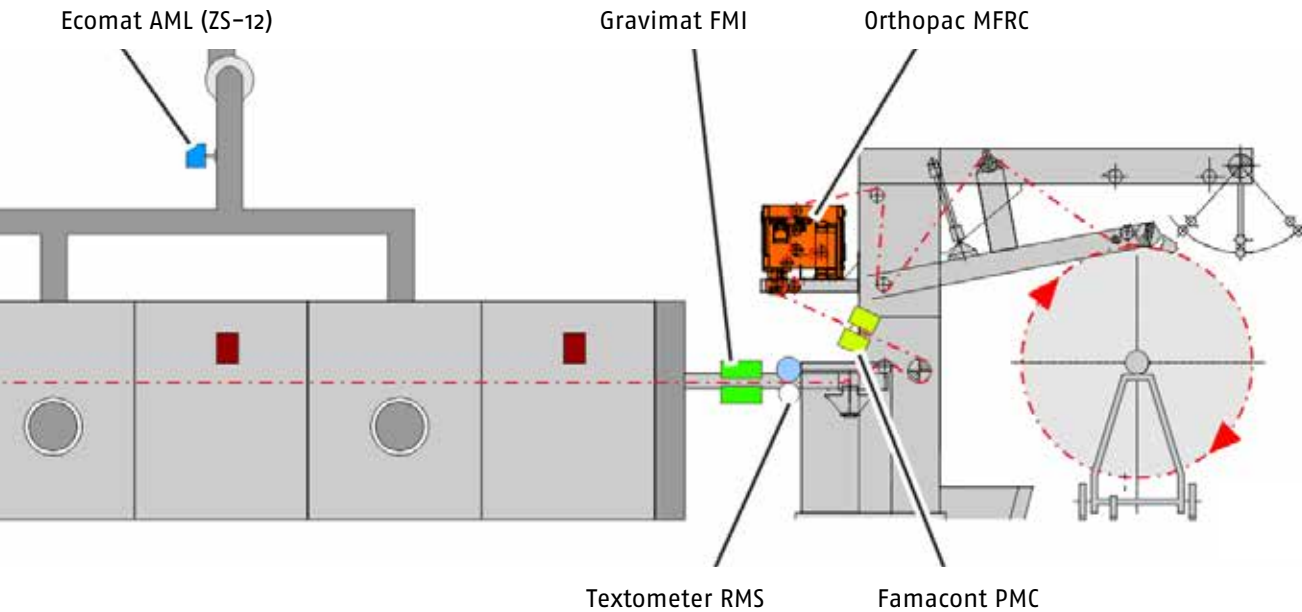

**Sensor overview**

Sensors		Measurand	Control variable
Permaset	VMT	Surface temperature Temperature trend Dwell time	Product web speed
Famacont	PMC	Thread density Course density	Over-feed
Gravimat	FMI	Weight	Over-feed, squeegee, speed
Textometer	RMS	Residual moisture	Product web speed
Ecomat	AML	Exhaust air moisture	Fan speed, flap opening
Wilot	WMR	Web width	–
Aqualot	HMF	High moisture	Compression pressure

## BASIS



# VISUALIZATION

EVERYTHING AT A GLANCE

All entries are made directly on the touchscreen using large, ergonomic buttons. Operation is simple and intuitive. All key information is visible at a glance.



Visualization and operation per touchscreen

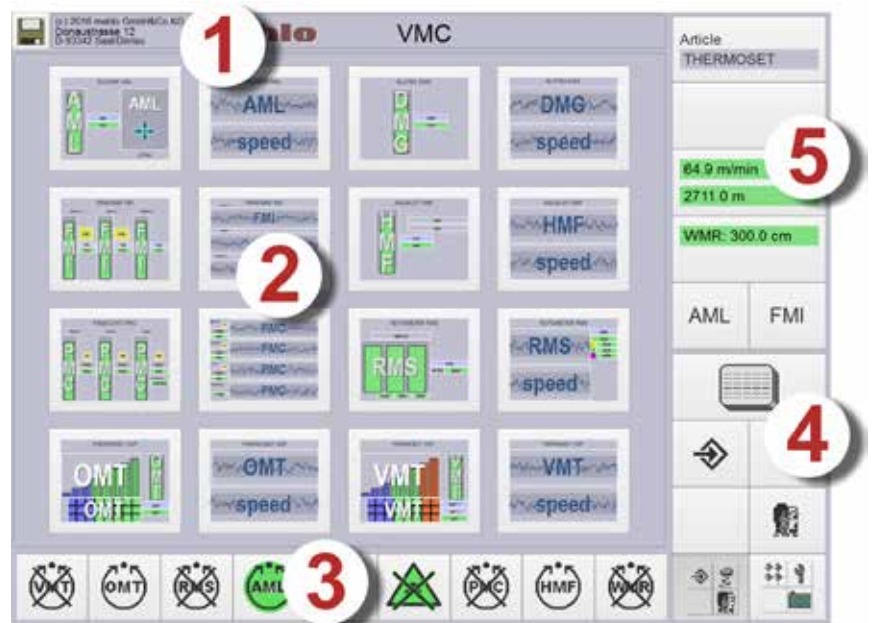

Main screen for selecting various sensors

**The user interface consists of five areas:**

**1. Title line:**

General information (including alarm bar)

**2. Display area:**

Selectable screen pages (display forms)

**3. Horizontal block:**

Operating buttons for basic functions and submenu

**4. Selection block:**

Navigation within the operating software

**5. Vertical block:**

Operating buttons for the menu selection

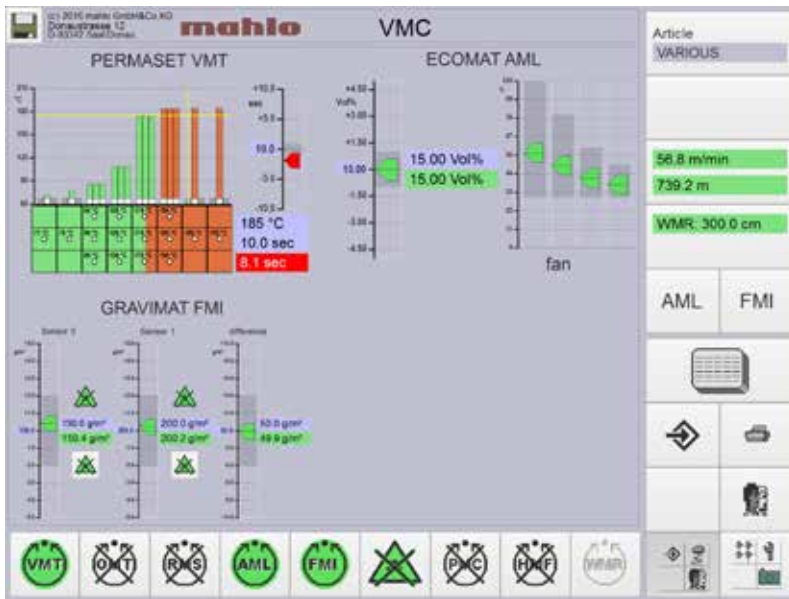

Display of values from various process control sensors

### Product highlights

- ✓ Simultaneous management of various sensors
- ✓ Freely scalable trend diagrams
- ✓ Password protection: Unauthorised users are prevented from accessing the program
- ✓ Recipe management

### Customer benefits

- ✓ All key data at a glance
- ✓ Menu guide in all common languages
- ✓ Ergonomic user prompting
- ✓ Simple operation

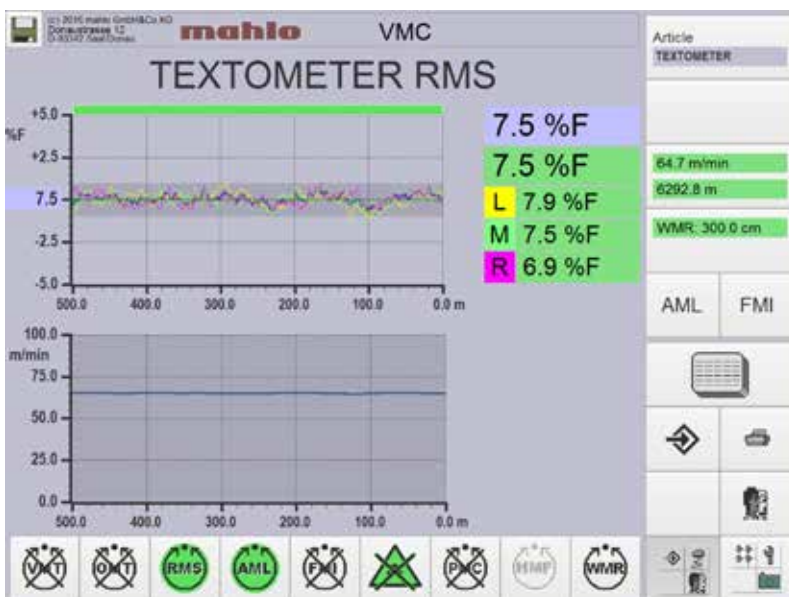

Trend diagram residual moisture and machine speed

## SENSORS



# PERMASET VMT

## DWELL TIME CONTROL



**Reliable dwell time control is indispensable for maximum economy of production and maximum product quality. Permaset VMT makes a key contribution to this end.**

### Area of application

Without knowledge of what's happening during a fixing, thermo-isolating, condensing or gelling process in the drying chambers, the stenter has to be looked at like a block box. The user had only his own experience to fall back on. Settings for circulation temperature and stenter speed have to be determined empirically. To ensure adequate process reliability most stenters are operated with large safety margins regarding possible speeds. They are therefore far away from optimal utilisation of machine capacity and energy invested.

In many processes knowledge of what happens in the stenter is not only an economic question. The achievable product quality also depends largely on the suitable temperature and dwell time. With thermo-fixing of textiles with Lycra portions excessive product temperatures may, for example, cause the Lycra portion to lose elasticity. This would mean significant quality reduction.

To ensure repeatable processes, the use of appropriate measuring equipment in the drier chambers is essential.

### Principle of operation

When wet product enters the dryer, it first heats up to the cooling limit temperature. When the water content drops to residual moisture levels, the product temperature begins to rise again. The closer the product temperature approaches the circulation air temperature in the dryer, the slower the temperature continues to rise. At a certain temperature threshold – called the fixing temperature – the temperature necessary for processing, fixing or condensing is reached.

To determine the dwell time for a desired product temperature, the surface temperature of the product is measured without contact at several locations in the dryer using high-temperature resistant infrared pyrometers. In addition, the Permaset VMT allows infrared pyrometers to be arranged across the width of the product (left,

### Product highlights

- ✓ Non-contacting product temperature measurement
- ✓ High-temperature rated sensors
- ✓ Little assembly and maintenance effort
- ✓ Self-cleaning sensors

### Customer benefits

- ✓ Highest repeatability
- ✓ Optimal utilisation of the stenter capacity
- ✓ Less energy required / yard goods
- ✓ Highest process reliability
- ✓ Short amortisation time
- ✓ Elimination of safety margins

middle, right). The system uses the trend of the rising temperature curve to determine with point accuracy when the preselected nominal temperature has been reached.

Depending on the product properties (material composition, product weight, initial moisture) this temperature is reached at different points in the dryer, so that multiple sensors are required (normally 3 to 8, and up to 64), to ensure adequate definition of the temperature trend. If the web speed is known, this can be used to determine and thereby regulate the time period during which the product is subjected to a given temperature. In addition to the qualitative aspect of reproducible maintaining of essentially constant process conditions, productivity can also be consistently increased and energy consumption optimised, since safety margins are no longer required. The practically observed increase in productivity, depending on the article, fabric length and extent of preceding optimisation efforts, ranges up to 30 %.

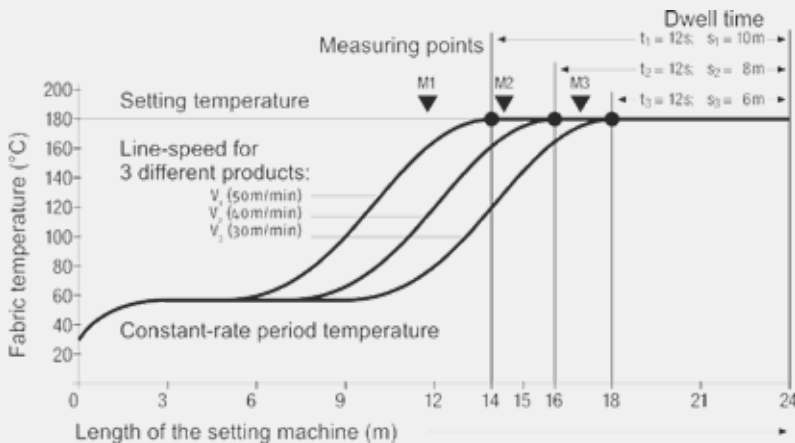
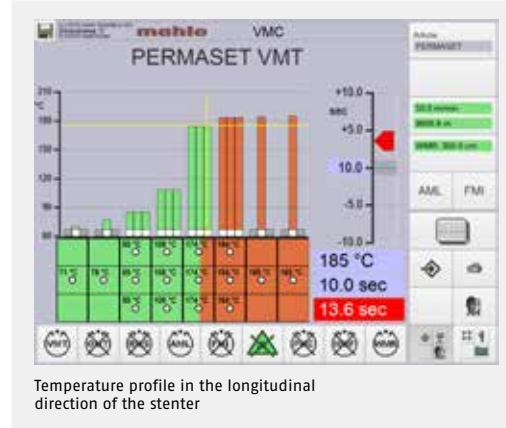

### DWELL TIME REGULATION

Automatic control allows the dwell time of the product to be precisely monitored in the stenter.

## SENSORS



# FAMACONT PMC

## WEFT THREAD AND COURSE DENSITY CONTROL



Continuous exact scanning of the weft thread or course density is an important factor for quality optimisation when finishing textile products.

### Area of application

The Famacont PMC is a reliable instrument for non-contacting, inprocess determination of the weft thread / course count.

Essential parameters such as weight, stretch / shrinkage are thus monitored and controlled. The Famacont PMC is an important tool for the finisher: Quality requirements of the customers are complied with; costs due to rejects and quality loss is minimised.

The system is very versatile. Stenter, shrinking and compacting equipment constitute the main application areas.

### Product highlights

- ✓ Non-contacting and continuous
- ✓ Determines the thread or knit density with the greatest accuracy using digital signal processing
- ✓ With "smart" feed forward control algorithm
- ✓ Universal application

### Customer benefits

- ✓ High repeatability
- ✓ Consistent residual shrinkage values
- ✓ Homogeneous product appearance
- ✓ Documentation of product quality
- ✓ Short amortisation times

### Principle of operation

The Famacont PMC determines the thread density by means of a non-contacting, optoelectronic or imaging process. The optoelectronic sensor determines the thread density in longitudinal direction (weft direction). With this process individual threads or courses pass the sensor and are projected onto the photocell using a precision optical lens. The resulting frequency is proportional to the thread count. The signal is amplified, prepared and digitally processed. Depending on the type of product, the sensor can work with transmitted light or reflex light.

With the imaging process the thread density can be determined at the same time in longitudinal and transverse direction (weft and warp direction). Images taken with a high-resolution camera are analysed with software (FFT analysis). The camera sensor is available



Famacont PMC with optoelectronic sensor (TK)



Famacont PMC with camera sensor (CK and CK HF)

in two versions: for normal thread densities up to 70 T/cm and for high thread density products up to 270 T/cm. Knowing the thread density both in weft and warp direction the imaging process also allows for conclusions as to the grammage of the product.

### Control strategy

A sophisticated feed forward control algorithm and two sensors ensure outstanding results. The first sensor detects the thread density before the infeed of the stenter and controls the over-feed with inclusion of the chain speed. Even with short-frequency changes in thread density the target value is immediately adjusted to the actual value as soon as the product arrives at the infeed. By optimising the weft thread and course density, homogeneous product appearance and consistent residual shrinkage values are achieved.

The second sensor logs weft thread and course density of the product at the outfeed of the stenter. An optional printer package is available to document the process statistics. Date transfer to higher level computer systems per host computer interface is possible.

The sensor at the infeed is usually integrated as additional scanner in the Orthopac straightening system. This makes any installation effort unnecessary. A holder with guide panels allows easy installation of the sensor and light source even when space is at a premium.

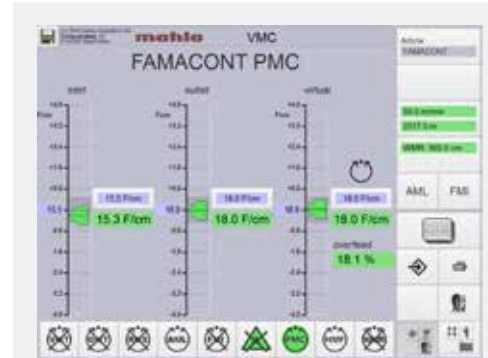

Thread count display

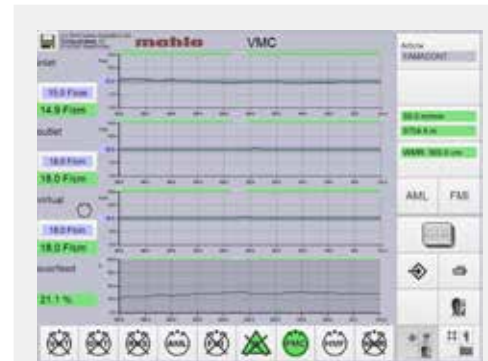

Thread density trend diagram



### SMART FEED FORWARD CONTROL

In order to achieve homogeneous product density and increased production yield, the Famacont PMC controls the over-feed direction fully automatically.

#### Overfeed Control

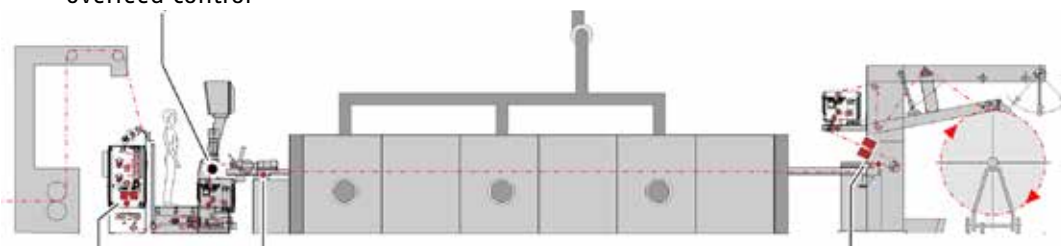

Infeed sensor    Reference chain speed

Outfeed sensor

Famacont PMC Smart-Feed-Forward Control on the stenter

## SENSORS



# GRAVIMAT FMI

## GRAMMAGE MEASUREMENT

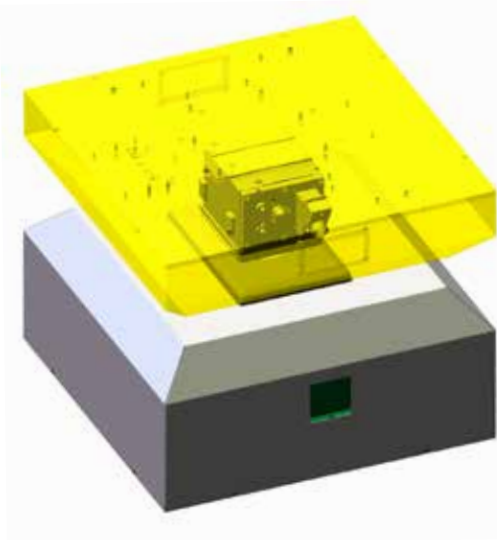

The weight monitoring and control system measures the grammage continuously and without contact on the moving product web.

### Area of application

The correct grammage is a decisive quality criterion in many process technologies in the textile industry and coating technology. Monitoring, control and logging of this parameter is therefore a decisive process step. The key is to determine the grammage under the given industrial conditions online and with high repeatability.

In addition to ensuring product quality, an appropriate setpoint with narrow tolerances can provide considerable savings in material and energy consumption, achieve process reliability while at the same time increasing production (see diagram).

### Product highlights

- ✓ Highest repeatability of the measured values
- ✓ Non-contacting measurement
- ✓ Digital signal processing
- ✓ Temperature compensation
- ✓ Source ageing compensation
- ✓ Gap compensation

### Customer benefits

- ✓ Material savings
- ✓ Quality assurance
- ✓ Increased production
- ✓ Comprehensive quality documentation

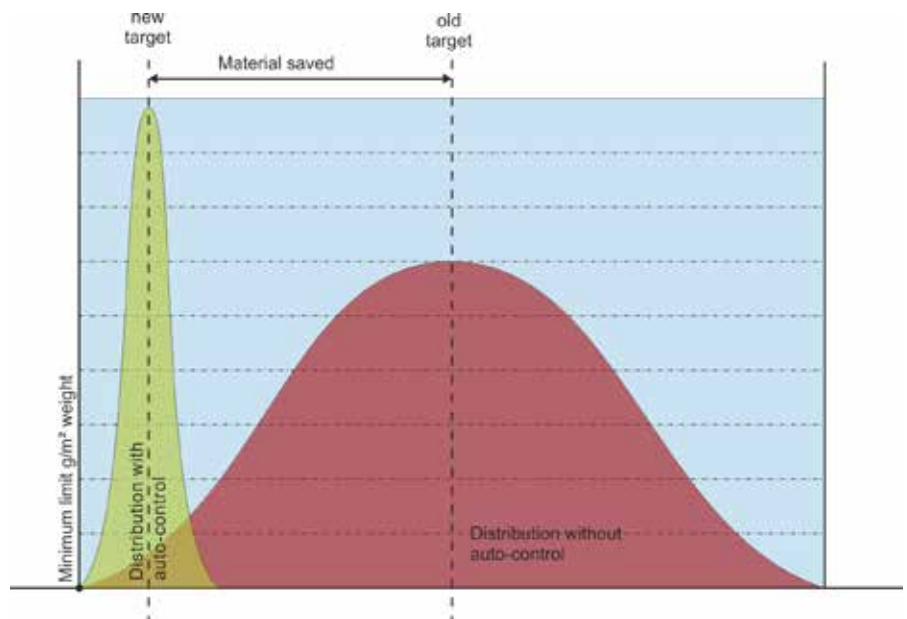



**RELIABILITY**

Our machines do exactly what we build them for: Hour after hour, year after year. Making sure you will always reach your goal.

**Principle of operation**

With the common grammage area measurement is based on the attenuation of radioactive rays through the material located in the measuring gap. This attenuation in intensity is an indication of the weight of the product. The grammage is hereby determined without contact and continuously at high accuracy.

For very different weight ranges, such as pile carpeting or coated textile bases, different nuclides are available. Differential measurements with two measuring points are normally made to control a coating process. The coating weight is continuously recorded in the process and the application or coating unit of the machine is automatically adjusted. This allows immediately responding even to short frequency changes of the incoming grammage.

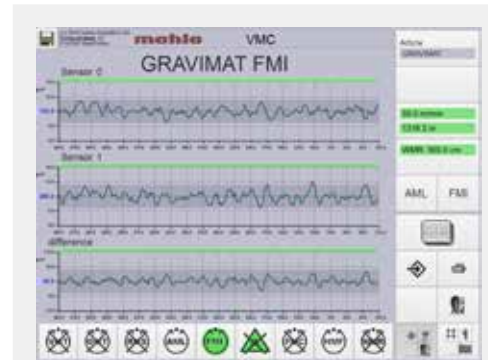

Grammage measurement trend diagram

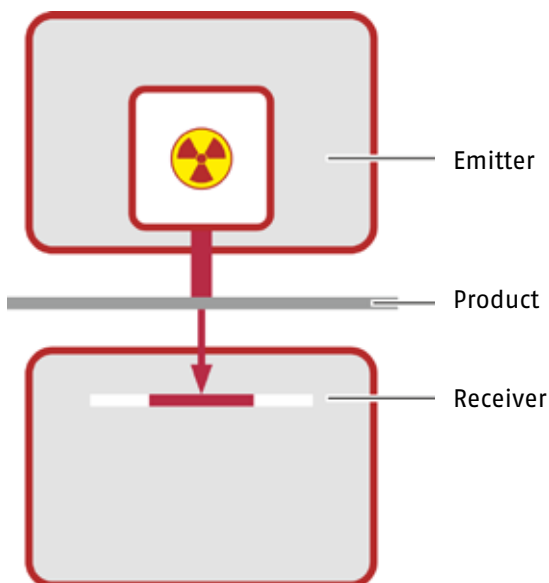

Principle of operation

## SENSORS



# TEXTOMETER RMS

## RESIDUAL MOISTURE CONTROL



**Economic drying means optimising the energy consumption and uniformity of the residual moisture to a target variable through permanent measuring of moisture and control of the drying process.**

### Area of application

One of the most important criteria in drying processes is the product moisture. The correct residual moisture of the product determines the economical factor in each drying procedure as well as the quality of the product and/or later finishing to a great extent.

Overdrying of the textile usually has a very negative effect on product appearance and feel. Residual moisture below the hygroscopic moisture balance results in weight loss and thus lower profits. If the textile is overdried in the stenter the drier speed drops significantly: an enormous reduction of the dryer capacity.

### Principle of operation

Of the electrically measurable properties of textiles, when it comes to residual moisture, conductivity is the one most strongly dependent on the water content of the textile substrate. Moisture differences of only a few percent change conductivity exponentially. When it comes to residual moisture, neither the thickness of the measured product nor the liquor composition have even remotely as strong an effect on electrical conductivity as the quantity of water in the measured product.

With most material compositions the residual moisture can be easily determined directly by measuring the electrical conductivity. A particular advantage of this method is that different textiles show specific moistures which differ from each other while having the same electrical conductivity. The individual calibration curves which depend on the material composition are already stored in the system. The electrical resistance between two poles of an electrode is meas-

### Product highlights

- ✓ Measurement of even low residual moisture values
- ✓ Highest repeatability
- ✓ Maintenance-free and reliable
- ✓ Variety of electrodes for different applications
- ✓ In special cases the left-centre/right moisture distribution can be determined

### Customer benefits

- ✓ Increased productivity and quality
- ✓ Optimal residual moisture for finishing
- ✓ Optimal use of dryer capacity
- ✓ Short amortisation time
- ✓ Improved profits
- ✓ Energy savings / yard goods

ured. Depending on the requirement this can be configured variously (e.g. electrode with a counter-roller, two rollers isolated from each other, etc.).

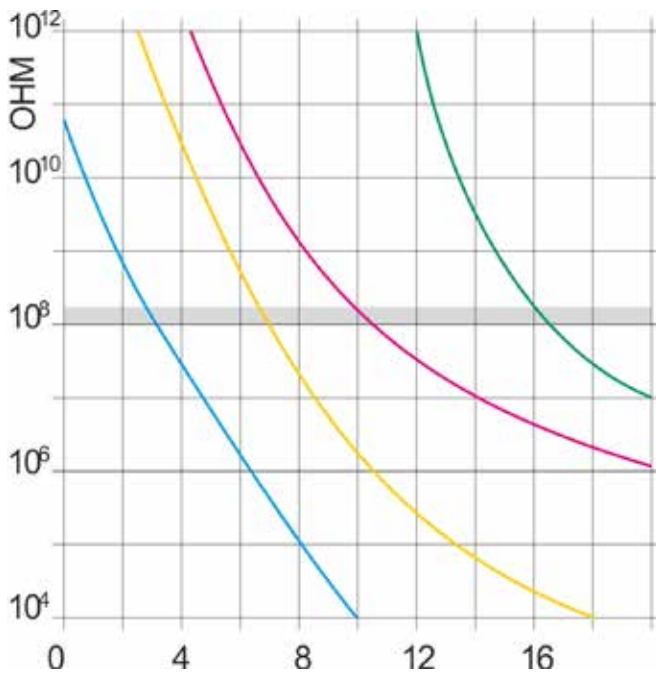

- Wool
- Viscose
- Cotton
- Polyamide
- Fibre moisture at x % relative humidity

Calibration curves for various fibre types

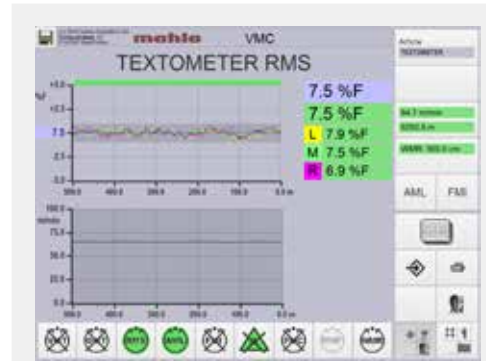

Residual moisture measurement trend diagram

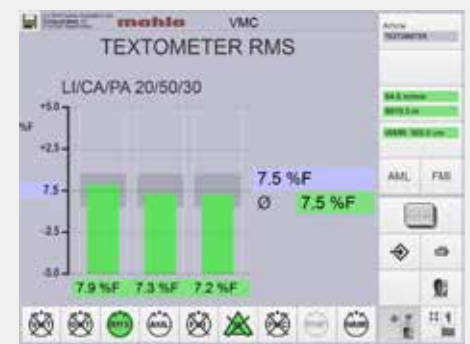

Display for moisture left, centre and right



Textometer RMS in use

## SENSORS



# ECOMAT AML

## EXHAUST AIR MOISTURE CONTROL



Much unused energy is wasted through the exhaust air during drying processes without appropriate control. The Ecomat AML adapts the heating energy to the actual demand by monitoring the vapour content of the exhaust air and controls this factor through the fan speed or the exhaust air vent control.

### Area of application

Large amounts of hot air are used to permanently evaporate new water (humidity), thus transporting the resulting mixture of hot air and water vapour out of the dryer. This mixing ratio is very important for the economy of the entire drying process. The amount of water to be evaporated during any period of time depends on the product weight, incoming and residual moisture, product width and transport speed. A constant fan speed or exhaust air flap position is not economic. The exhaust air humidity needs to be constantly measured and the setting of the fan speed or exhaust air flap setting automatically regulated.

### Principle of operation

The Ecomat AML measures the exhaust air humidity with a zircon oxide sensor which determines the exact steam and oxygen content. The elementary oxygen is ionised at this at a defined tension. The proportion of oxygen and steam is determined from the resulting currents. This sensor is temperature-resistant and features a kind of self-cleaning effect, since any contaminating organic substances on the hot measuring cell are immediately burned off.

### Product highlights

- ✓ Highest measuring accuracy
- ✓ Unaffected by carrier gases
- ✓ Measures oxygen, water vapour and harmful gas proportion
- ✓ Low-maintenance
- ✓ Self-cleaning
- ✓ Rugged construction

### Customer benefits

- ✓ Optimised energy efficiency
- ✓ Energy saving
- ✓ Increased process repeatability
- ✓ Quality improvement
- ✓ Short amortisation time



Typical sensor installation

This significantly reduces maintenance requirements for the sensor. The signal of the sensor is used to select an exhaust air fan or flap adjustment drive. Fans or exhaust air flaps can be controlled with up to four control outputs. The display of the measured absolute moisture can take place in vol.-% H<sub>2</sub>O, g/kg or °C dew point.

The graph shows to what degree the heating costs of a dryer are dependent on the required volume of fresh air and thereby the vapour content in the exhaust air. Whereas the evaporation curve is relatively flat, the cost index quickly rises especially for a wideopen exhaust air flap, i.e. low vapour content. The fan speed should be set so that the humidity in the exhaust air is as high as possible without noticeably reducing production output.

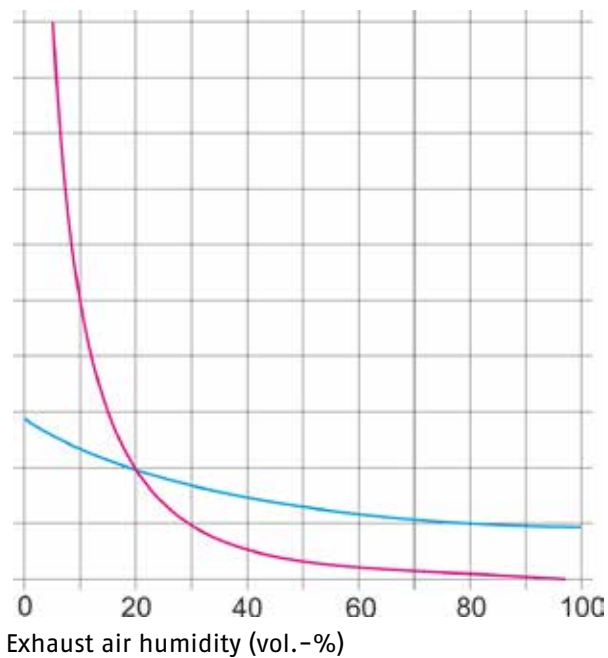

■ Relative fresh air volume, cost index      ■ Relative evaporator output



**KNOWLEDGE**

We have a common goal: Maximum performance for your system. To this end we are by your side from installation to maintenance of the machines to training of your employees. We provide comprehensive training to your staff for operation and maintenance. You will thus be able to solve problems even faster.

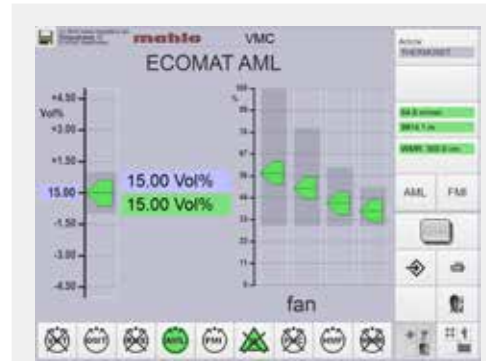

Actual value / target value display

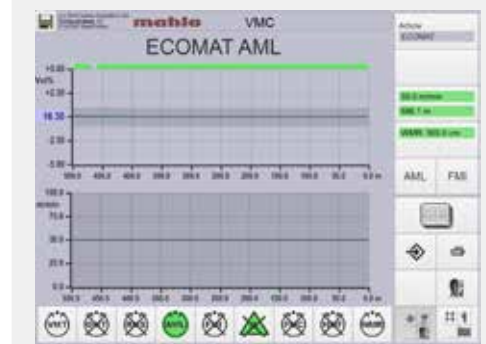

Exhaust air moisture trend diagram

## SENSORS



# WILOT WMR

## PRODUCT WIDTH MEASUREMENT



### Area of application

The Wilot WMR is a reliable instrument for non-contacting, inprocess determination of the product width, especially at the stenter delivery end. The Wilot WMR helps suppliers to maintain the quality specifications of their customers and reduce costs from scrap and quality problems.

The system is very versatile. Stenters and levelling stenters represent the main application areas.

### Product highlights

- ✓ Non-contacting and continuous
- ✓ Determines the product width with greatest accuracy using digital signal processing
- ✓ Universal application

### Customer benefits

- ✓ High repeatability
- ✓ Homogenous product appearance
- ✓ Documentation of product quality
- ✓ Short amortisation time



### Principle of operation

IR LEDs used as retro-reflective devices determine the product width. The operator can set the sensitivity of the sensors from the included control panel, and specify the maximum and minimum product width for alarm functions. Since the sensor module only needs to be attached on one side of the product, mounting options are very flexible.

The unit consists of:

- Sensor module
- Electronics
- Control panel
- Digital display (optional)

Different models are available to cover a wide variety of applications:

- Stand-alone version with digital display
- Module version with visualisation on an Optipac or Orthopac

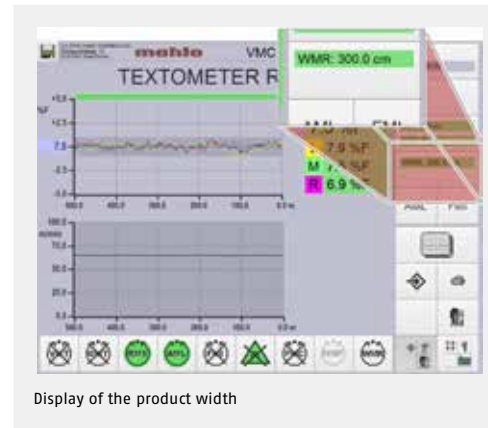

Display of the product width



Quality made  
in Germany

For decades we have been developing and producing our machines exclusively in Germany – using highly motivated specialists we have trained ourselves. This is your guarantee of the highest level of quality.

## TECHNICAL DATA | OPTIPAC VMC



Basis	Optipac VMC
Power connection	1 x 230 VAC, 50/60 Hz, transformer station available for other voltages
Power consumption, max.	3,0 kVA
Temperature range (standard)	+5 – +45 °C
Temperature range (with A/C unit)	+5 – +50 °C
Temperature range control and display station	-20 – +45 °C
Relative humidity (non-condensing)	0 – 95 %
Maximum setup elevation a.s.l.	1000 m
IP protection class	IP 54
Dimensions	600 x 1664 x 485 mm (W x H x D)
Weight	80 kg

## Dimensions

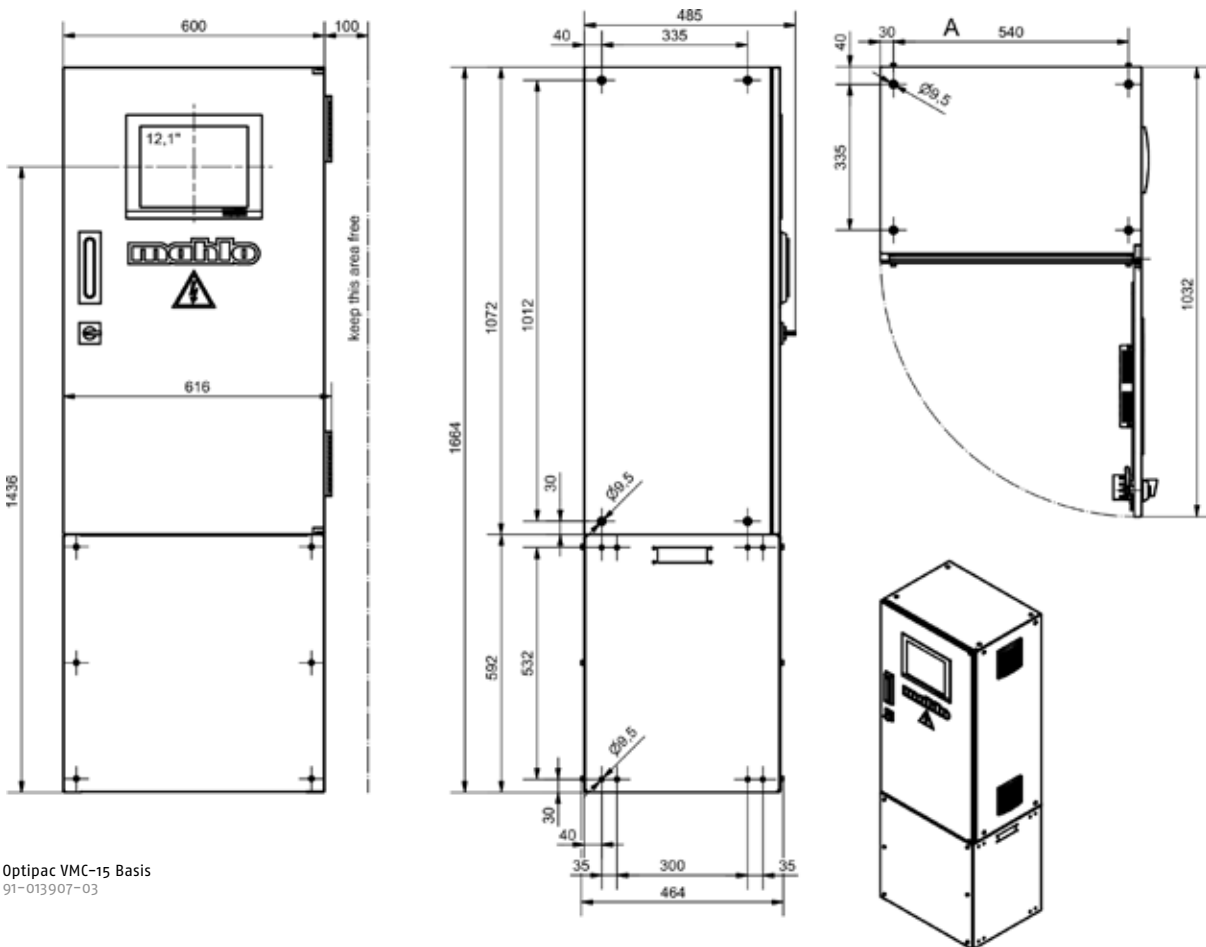

Optipac VMC-15 Basis  
91-013907-03



### FIRST AID

You can count on our service team, especially when 'first-aid' is required. A call is all it takes to get our technicians on-site. Around the clock – and around the globe. So that you can concentrate on your work without worry.



Online-Support:

**SERVICE@MAHLO.COM**

Support-Hotline:

**+49-(0)180-50 62 456**

## TECHNICAL DATA | PERMASET VMT



Sensor	Permaset VMT
Measuring range	0 – 250 °C
Measuring field	Field of view 120°
Measuring accuracy	≤ 1 % of readout range at 23 °C
Response time	$t_{0,9} = 6 \text{ s}$
Output signal	CAN, analogue 0 – 20 mA
Temperature range	Measuring amplifier: 0 – +85 °C Sensor with cable: 0 – +250 °C
Climate class	KPA according to DIN 40040

Mechanical Data	Sensor	Measuring amplifier
Design	Stainless steel housing, 6 m connecting cable in Teflon design	Aluminium die-cast housing
IP protection class	IP 65	IP 67

**Dimensions**

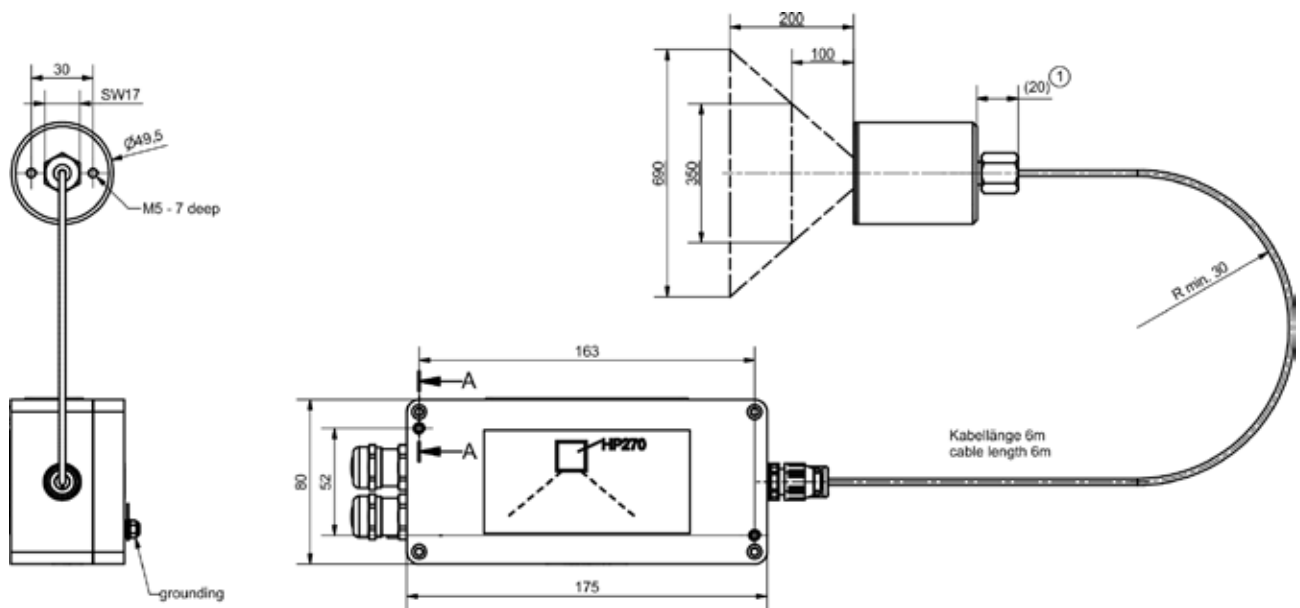

Sensor Permaset VMT  
91-015449

## TECHNICAL DATA | FAMACONT PMC



Sensor	Famacont PMC
Measuring principle	Continuous optoelectronic scanning (transmitted light or reflex light) or imaging scanning
Measuring range	Optoelectronic sensor TK: up to 220 threads/cm Camera sensor: CK up to 70 threads/cm; CK HF up to 270 threads/cm (depends on web speed and type of fabric)
Max. product speed	150 m/min (depending on thread count and type of fabric)
Permissible distortion angle	$\pm 40^\circ$
IP protection class	IP 54
Temperature range	0 – 50 °C
Relative humidity (non-condensing)	0 – 95 %



### INNOVATIONS

We love being technology leaders. And our development team works every day to make sure it remains so. Innovations, inventive talent and future-oriented thinking – to guarantee your success.

**Dimensions**

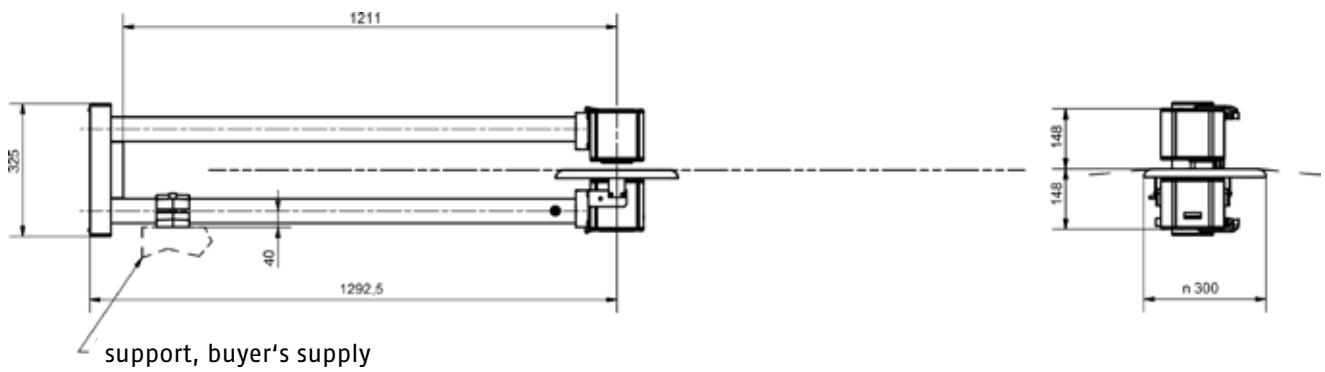

Sensor Famacont PMC;  
version with fork and plate  
91-013415

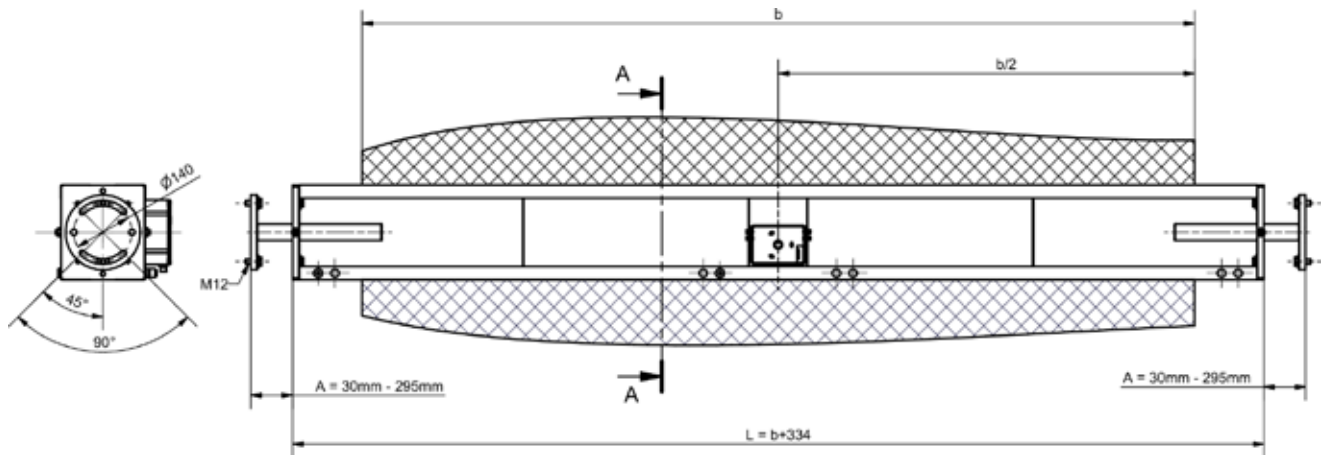

Sensor FAMACONT PMC  
version with guide panel  
91-013336-02

## TECHNICAL DATA | GRAVIMAT FMI



Sensor	Gravimat FMI	
Isotope	Krypton-85 (Kr-85)	Strontium-90 (Sr-90)
Activity	3,0 GBq 9,62 GBq	500 MBq
Measuring range	10 – 1400 g/m <sup>2</sup>	
Repeatability (2 , 1s) (whichever value is greater)	±0.1 % or ±0.1 g/m <sup>2</sup> (80 mCi : t = 4 s)	±0.3 % or ±0.5 g/m <sup>2</sup>
Measuring gap height	10 – 100 mm	10 – 100 mm
Temperature compensation	At 4 locations (one each for the emitter and receiver housing, and one each above and below in the measuring gap)	
Barometric compensation	Electronic (included in control and display station)	
Temperature range	+10 – +60 °C (with sensor cooling) Use at higher temperatures upon request	
Relative humidity (non-condensing)	0 – 95 %	

**Dimensions**

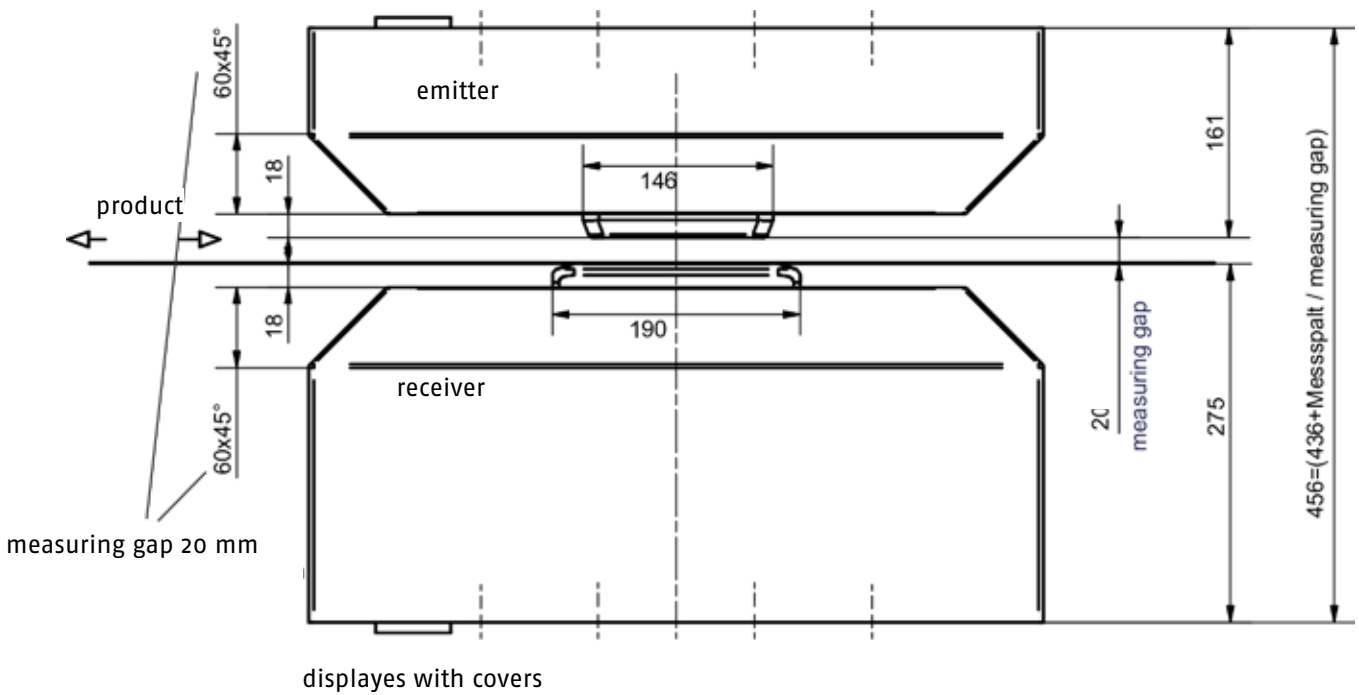

Sensor GRAVIMAT FMI  
91-013098-03



**PERSONALITY**

You're not just a number for us. Your individual needs and special requirements are our highest priority. We are there for you with our expertise, our leading technology and full dedication. So you can always play to win.

## TECHNICAL DATA | TEXTOMETER RMS • ECOMAT AML



Sensor	Textometer RMS
Fibre types and mixtures	Freely selectable from the list, calibration curves stored; not suitable for isolators (glass, 100 % PA, etc.) or electrical conductors (metal fibres or filaments)
Measuring range	Depending on fibre type, fibre mixture and electrode type Examples: - cotton: 3 – 20 % - Linen: 7 – 43 % - Linear scale: 0 – 100 scale (low humidity electrode: from 1 %)
Measurement display	Standard electrode (1-channel): highest moisture value 3-channel electrode: highest value, lowest value or arithmetical average
Temperature range	Measuring amplifier: 0 – +50 °C
Measuring electrodes	Different versions for outside attachment or inside installation in sizing machines and driers of all types. Dimensions and weights according to design.

### Dimensions

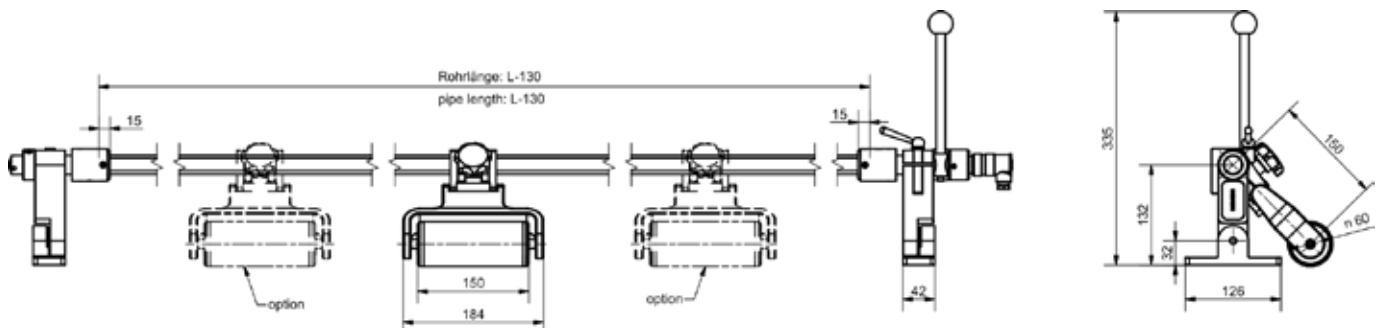

Sensor TEXTOMETER RMS  
91-013151-07

Sensor	Ecomat AML
Measuring range	H <sub>2</sub> O 0 – 100 Vol.-%
Measuring accuracy	≤ 2 vol.- % of the top-end of range
Output signal	0 – 20 mA, 4 – 20 mA
Temperature range	Measuring amplifier: 0 – +65 °C Sensor: 0 – +300 °C
Climate class	JWE according to DIN 40040

Mechanical Data	Sensor	Measuring amplifier
Design	Stainless steel housing	Aluminium die-cast housing
IP protection class	Only measuring gas allowed	IP 67

### Dimensions

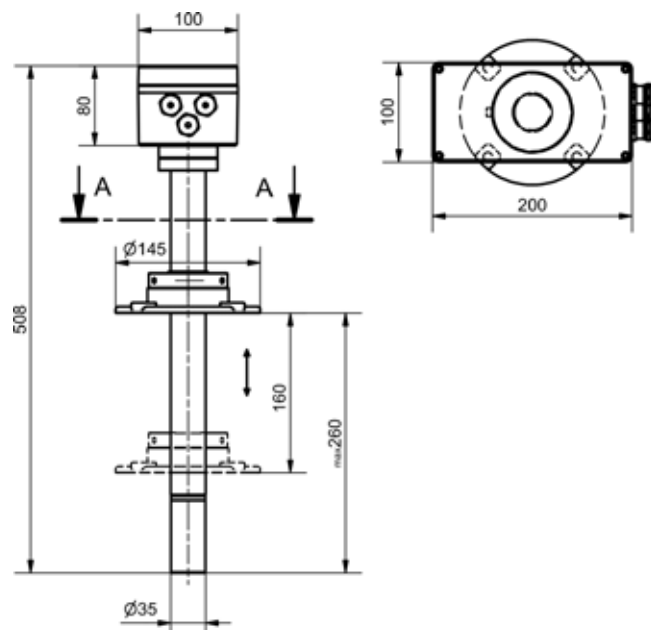

Sensor ECOMAT AML  
91-015470-01

## TECHNICAL DATA | WILOT WMR



Sensor	WILOT WMR
Product width detection	IR LEDs, retro-reflective technique
Measuring accuracy	±5 mm (each side)
Max. product width	6000 mm
IP protection class	IP 54

**Dimensions**

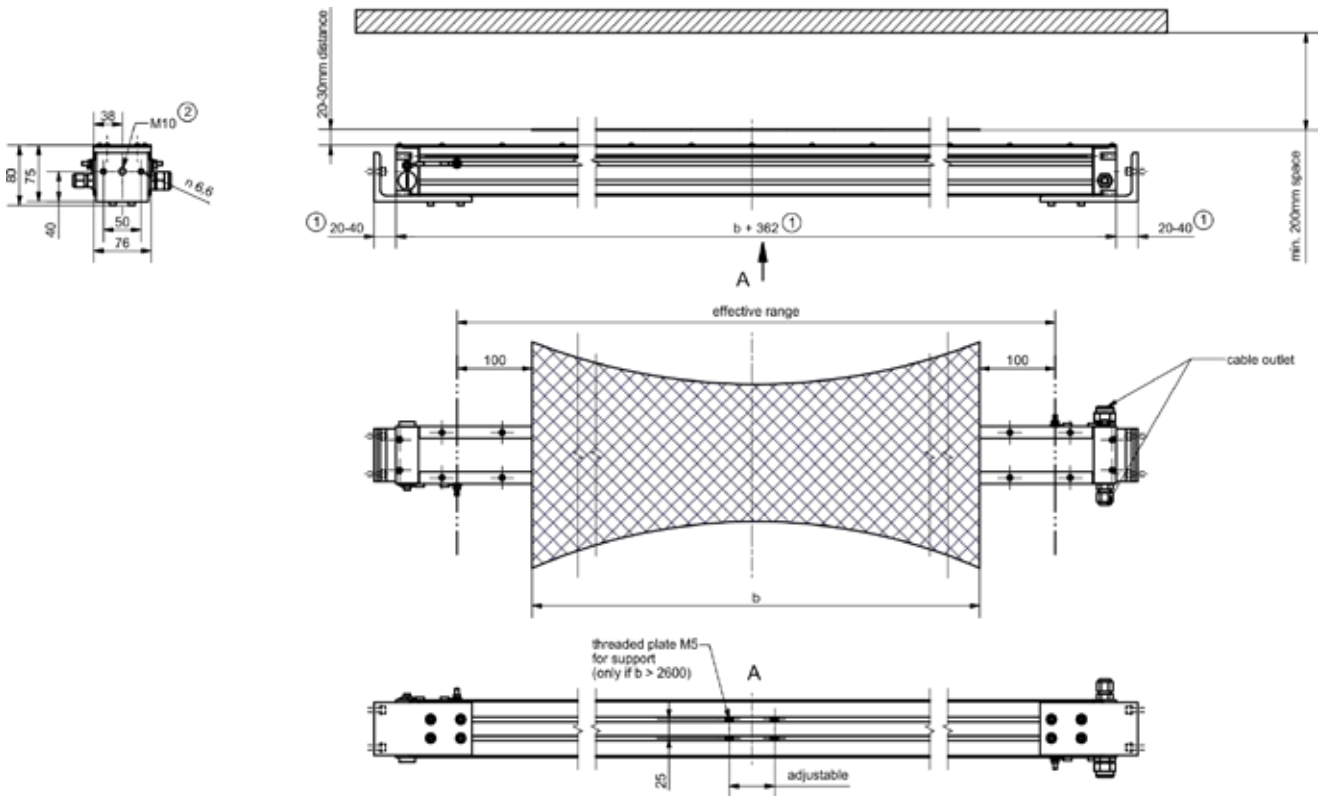

$b$  = product width  
all dimensions in mm  
If product width exceeds 2600mm, the user company should provide a central support for the sensor

Sensor WILOT WMR  
91-013867

Monitoring and control systems, automation

# MAHLO® GUARANTEES QUALITY. WORLDWIDE, IN YOUR VICINITY.

Best-possible technical support and know-how transfer are written in capital letters at Mahlo. Thanks to an international network of agencies and service centres, customers have at their disposal competent support worldwide. We are there for you. Just get in touch with us!

- ✓ Service partners in over 100 countries
- ✓ Direct on-site service and fast delivery of spare parts
- ✓ Remote diagnostic system
- ✓ Service-Hotline: +49-180-5062456
- ✓ [www.mahlo.com](http://www.mahlo.com)



**Mahlo GmbH + Co. KG Germany**

Donaustr. 12, 93342 Saal/Donau  
Tel.: +49-9441-601-0  
Fax: +49-9441-601-102  
[info@mahlo.com](mailto:info@mahlo.com)

**Mahlo Italia S.R.L. Italy**

Via Fiume 62, 21020 Daverio  
Tel.: +39-0332-94-95-58  
Fax: +39-0332-94-85-86  
[mahlo.italia@mahlo.com](mailto:mahlo.italia@mahlo.com)

**Mahlo America Inc. USA**

575 Simuel Road, Spartanburg, S.C. 29304  
Tel.: +1-864-576-62-88  
[mahlo.america@mahlo.com](mailto:mahlo.america@mahlo.com)

**Mahlo Ouest S.R.L. Belgium**

Quartum Center  
Hütte 79 - Bte 10  
4700 Eupen  
Tel.: +32-87-59-69-00  
Fax: +32-87-59-69-09  
[mahlo.ouest@mahlo.com](mailto:mahlo.ouest@mahlo.com)

**Mahlo España S.L. Spain**

Calle Luxemburgo nº 4  
08303 Mataró (Barcelona)  
Tel.: +34-938-640-549  
[mahlo.espana@mahlo.com](mailto:mahlo.espana@mahlo.com)

**WWW.MAHLO.COM**



Quality made  
in Germany