

ECOSENSE ZS-12

Exhaust air humidity up – Energy down!

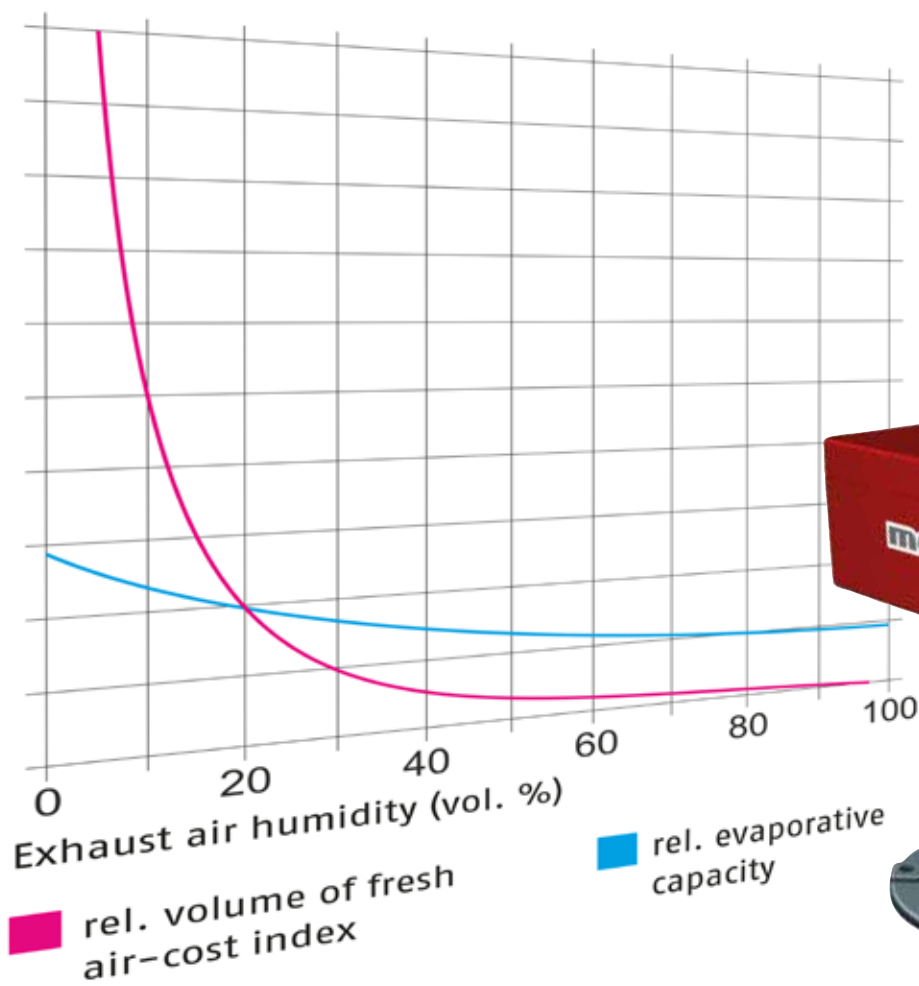

ECOSENSE ZS-12



TEXTILE NONWOVEN COATING & CONVERTING EXTRUSION BATTERY PAPER

EXHAUST AIR HUMIDITY CONTROL

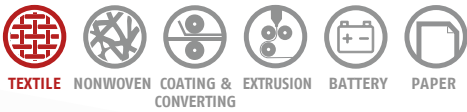

ECOSENSE ZS-12

EXHAUST AIR HUMIDITY UP – ENERGY DOWN!



Much unused energy is wasted through the exhaust air during drying processes without appropriate control. The humidity sensor ZS-12 adapts the heating energy to the actual demand by monitoring the vapour content of the exhaust air and then controls this factor through the fan speed or the exhaust air vent control.

- The energy demand is reduced by the controlled heating demand.
- The constant conditions produced by the control increase the reproducibility of the production process and the product quality.

Product-highlights

- ✓ Non-contact measurement of product temperature
- ✓ High-temperature proof sensors
- ✓ Low maintenance requirements
- ✓ Easy to install
- ✓ Self-cleaning sensors

Customer benefits

- ✓ Maximum repeatability
- ✓ Optimal utilisation of stenter capacity
- ✓ Low energy consumption per meter of product
- ✓ Ultra-reliable processing
- ✓ Short payback times
- ✓ Elimination of safety margins

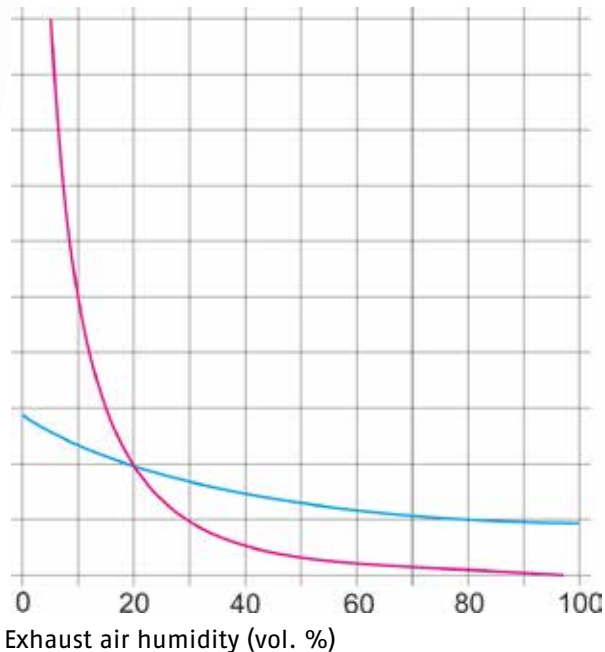

■ rel. volume of fresh air-cost index

■ rel. evaporative capacity

Maximising the exhaust air moisture from 8 to 15 vol. % results in

- reduction of energy consumption by 23 %
- reduction of production costs by 6 %
- maintaining a consistent production speed.

Prerequisite: Working time 240 days/at 3 shifts; product weight: 150 g/m²; product width: 1.6 m; initial moisture: 75 %; residual moisture: 4 %; product speed: 100 m/min; fresh air: 25 °C; exhaust air: 160 °C

Sensor	Ecosense ZS-12		
Measuring range	H ₂ O 30/50/100 Vol. %; 266/622/1000 g/kg;		
Accuracy	≤ 2 Vol. % of maximum scale reading		
Sensor ports	0-20 mA, 4-20 mA		
Max. working temperature	Sensor controller:	0...+65 °C	Sensor: 0...+ 250 °C
Power supply	24 V DC, 0,5 A; 24 V AC, 0,7 A		
Connection	3 EMC cable glands M16 x 1,5, with shield clamping range, protection class IP 67		
Sound pressure level	< 70 dB (A)		
Mechanical data	Sensor	Sensor controller	
Construction	Stainless-steel stem	Die-cast aluminium casing	
Proofing standards	Against measured gases only!	IP 67	
Weight	28 N (~ 2,8 kg)		

Dimensions

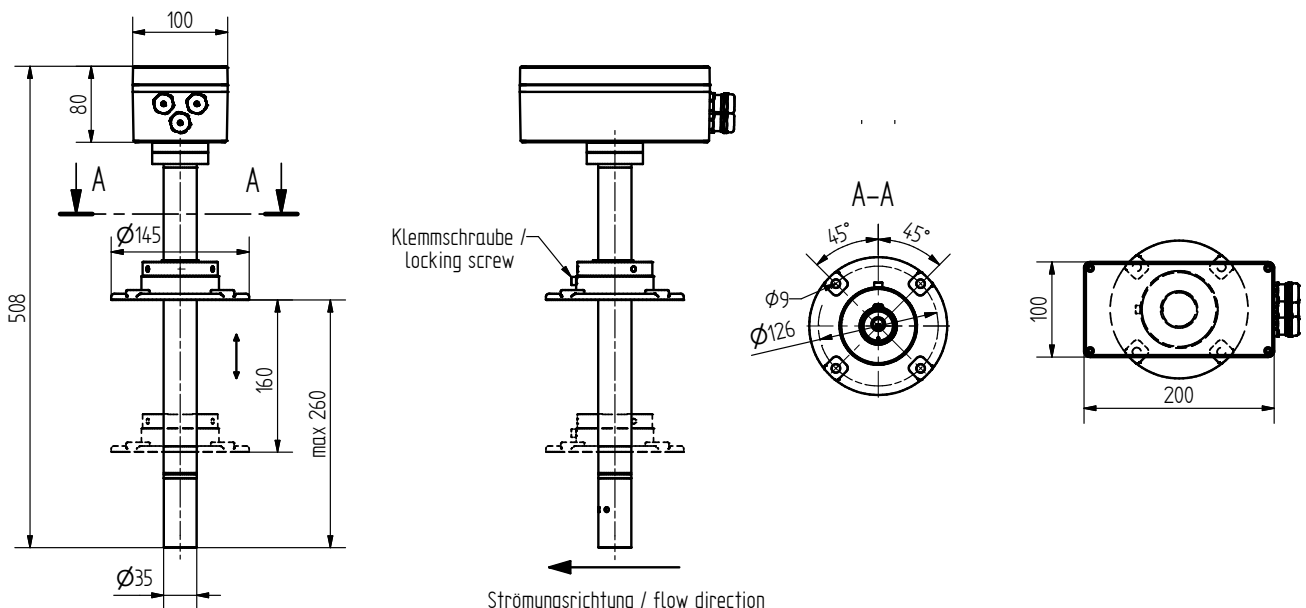

Ecosense ZS-12
91-015470-01

Monitoring and control systems, automation

MAHLO® GUARANTEES QUALITY. WORLDWIDE, IN YOUR VICINITY.

Best-possible technical support and know-how transfer are written in capital letters at Mahlo. Thanks to an international network of agencies and service centres, customers have at their disposal competent support worldwide. We are there for you. Just get in touch with us!

- ✓ Service partners in over 100 countries
- ✓ Direct on-site service and fast delivery of spare parts
- ✓ Remote diagnostic system
- ✓ Service-Hotline: +49-180-5062456
- ✓ www.mahlo.com



Mahlo GmbH + Co. KG Germany

Donaustr. 12, 93342 Saal/Donau
Tel.: +49-9441-601-0
Fax: +49-9441-601-102
info@mahlo.com

Mahlo Italia S.R.L. Italy

Via Fiume 62, 21020 Daverio
Tel.: +39-0332-94-95-58
Fax: +39-0332-94-85-86
mahlo.italia@mahlo.com

Mahlo America Inc. USA

575 Simuel Road, Spartanburg, S.C. 29304
Tel.: +1-864-576-62-88
mahlo.america@mahlo.com

Mahlo Ouest S.R.L. Belgium

Quartum Center
Hütte 79 - Bte 10
4700 Eupen
Tel.: +32-87-59-69-00
Fax: +32-87-59-69-09
mahlo.ouest@mahlo.com

Mahlo España S.L. Spain

Calle Luxemburgo nº 4
08303 Mataro (Barcelona)
Tel.: +34-938-640-549
mahlo.espana@mahlo.com

WWW.MAHLO.COM



Quality made
in Germany